

GENELEC®

4430A



See Genelec Accessories Catalogue on www.genelec.com for a complete list of mounting hardware options. The accessories can come with instructions on the proper methods of installation.

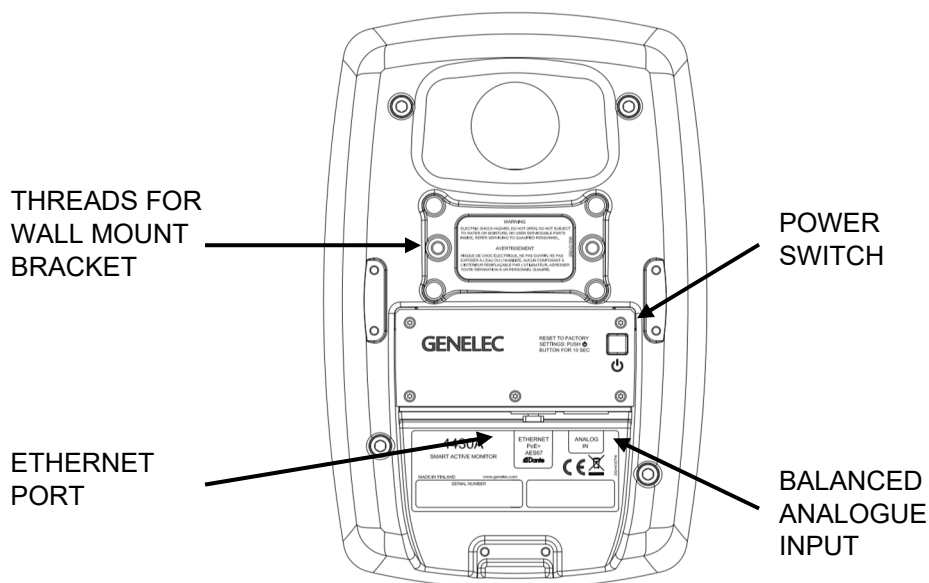

Figure 3. Connectors and controls in the 4430A rear panel.

CONNECTING LOUDSPEAKERS

To get started, connect an Ethernet cable from the PoE+ output in an IP switch to the 4430A Ethernet port. Use at least CAT5 cable or better. Press the power switch to power up the loudspeaker.

To create a working system, you will need

- IP switch with a PoE+ (802.3at) output for the 4430A loudspeaker or an IP switch with no PoE support and a PoE+ power injector
- CAT 5 or higher category Ethernet cable with RJ45 connectors
- AES67, ST2110 or Dante audio-over-IP stream source
- For 4430A setup and configuration, a computer running Macintosh OS X or Windows 10 operating system
- Genelec Smart IP Manager software
- Dante Controller software or Dante Domain Manager software

Specifications

SYSTEM SPECIFICATIONS	
Lower cut-off frequency, -6dB	≤ 45 Hz
Upper cut-off frequency, -6dB	> 39 kHz
Frequency response within ± 1.5 dB	58 Hz – 20 kHz
Minimum delay from analogue input to acoustic output	2.3 ms
Maximum short-term sine wave output on axis in half space, average 100 Hz to 3 kHz, at 1 m, using PoE+ power	≥ 104 dB SPL
Maximum long-term RMS acoustic output in same conditions with IEC-weighted noise, at 1 m using PoE+ power (limited by driver unit protection circuit and the PoE power supply being used)	≥ 96 dB SPL
Maximum peak acoustic output per unit in a listening room with music material, at 1 m, using PoE+ power	> 107 dB SPL
Self-generated noise level in free space, at 1 m on the acoustical axis, A-weighted	≤ 5dB
Harmonic distortion at 85 dB SPL at 1 m on axis frequency range 50 – 200 Hz frequency range >200 Hz	< 2% < 0.5%
Dispersion angle (degrees), horizontal	120°
Dispersion angle (degrees), vertical	100°
Bass driver	130 mm (5 in) cone
Treble driver	19 mm (3/4 in) metal dome
Weight	5.1 kg
Height	285 mm (11 1/4 in)
Width	189 mm (7 7/16 in)
Depth	178 mm (7 in)

Maximum short-term output level is limited by the PoE technology being used and the crest factor of the audio signal. The stated values are typical for music and speech signals.

Maximum long-term output level can be further limited by loudspeaker system protection. Genelec recommends using PoE+ whenever possible. Using lower-power PoE can limit short-term maximum and long-term maximum, depending on the characteristics of the signal being reproduced.

User selectable filters can be set to positive gain. Positive gain must be used with care as it is possible to cause premature overload of the loudspeaker at specific frequencies.

INPUT / CROSSOVER SECTION	
Ethernet connection	100BASE-TX 1 x RJ45
Nominal SPL with 0 dBFS digital audio input at maximum sensitivity	130 dB SPL
Audio-over-IP streaming formats	AES67, ST2110-30, Dante
Analogue input, connector type	3 pin Euroblock
Analogue input, Input impedance	10 kOhm, balanced
Analogue input level for 100 dB SPL at 1 m	-6 dBu
Analogue input, maximum input signal	24dBu
Crossover frequency, bass/treble	2.9 kHz
Number of user-adjustable filters	20
User selectable filters, choice of function for each user-adjustable filter	parametric notch high frq. shelf low frq. shelf bass roll-off bass tilt treble tilt
User selectable filters, parameter adjustment ranges for a notch filter <ul style="list-style-type: none"> • gain • Q-value • center frequency 	-20...+2 dB 0.1...20 10 Hz...16 kHz
Sensitivity, adjustment range	-60...0 dB
Delay, adjustment range	0...98 ms

AMPLIFIER SECTION	
Bass amplifier output power, short-term	50W
Treble amplifier output power, short-term	50W
Supply power at switch, power-over-Ethernet PoE+ (Class 4) PoE (Class 3)	30 W 15.4 W
Supported PoE standards PoE+ (supports signature and LLDP) PoE (supports signature)	IEEE 802.3at IEEE 802.3af
CAT cable specification	5, 5e, 6
Maximum CAT cable length	100 m (333 ft)
Power consumption in idle	5 W
Power consumption in ISS power-down mode	4 W

MEASUREMENTS

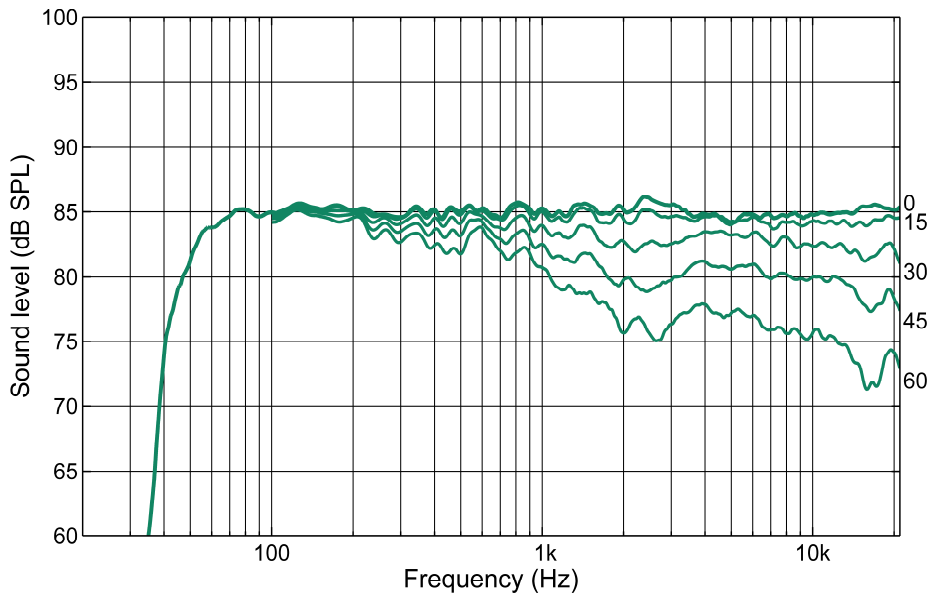

Figure 11. Frequency responses on the horizontal plane. Off-axis angle indicated in degrees.

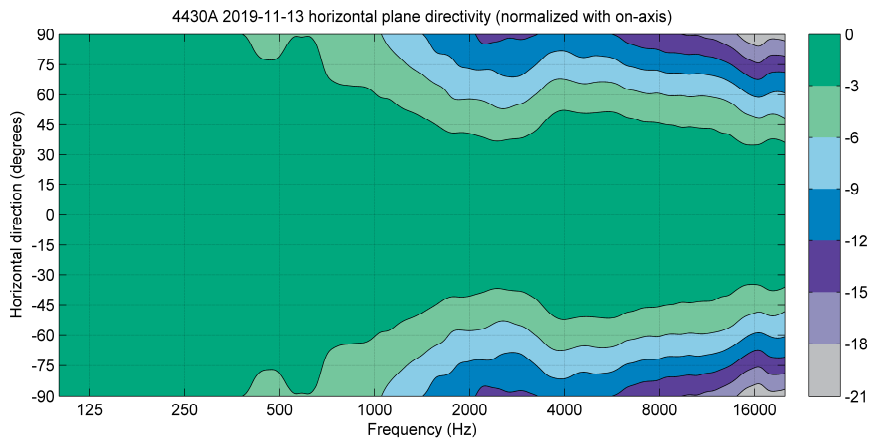

Figure 12. Horizontal directivity plot of the 4430A. Colour bar indicates dB level.

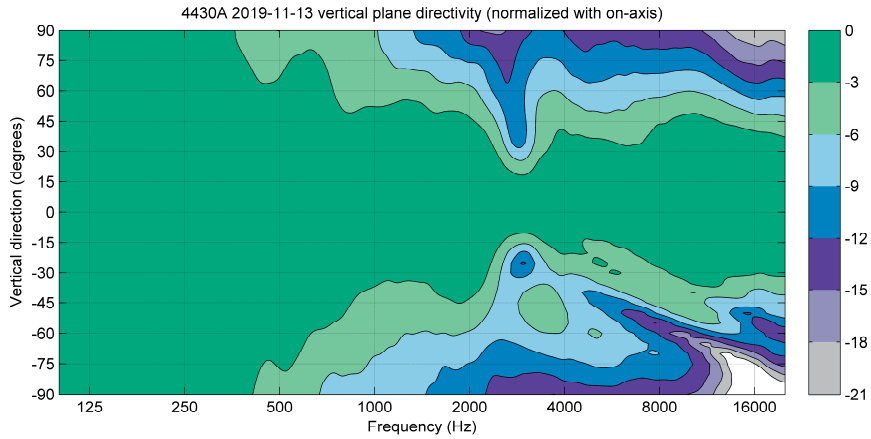

Figure 13. Vertical directivity plots of the 4430A. Colour bar indicates dB level.

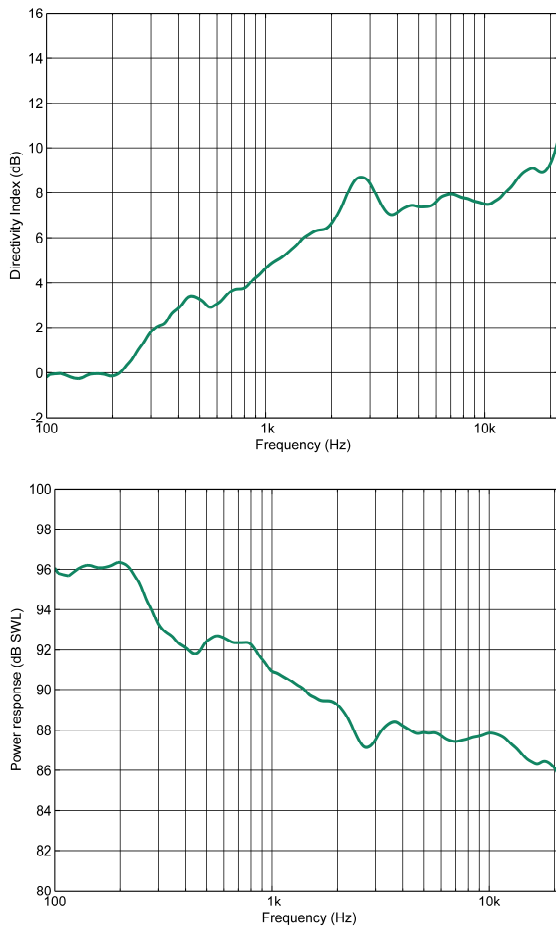

Figure 14. Directivity index (top) and power response (bottom).

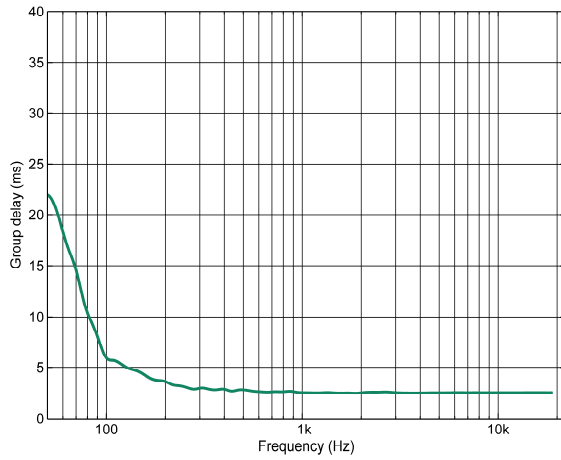

Figure 15. System delay from the analogue signal input to the acoustic output. For the audio-over-IP stream input, additional delay may result from the audio-over-IP transport.

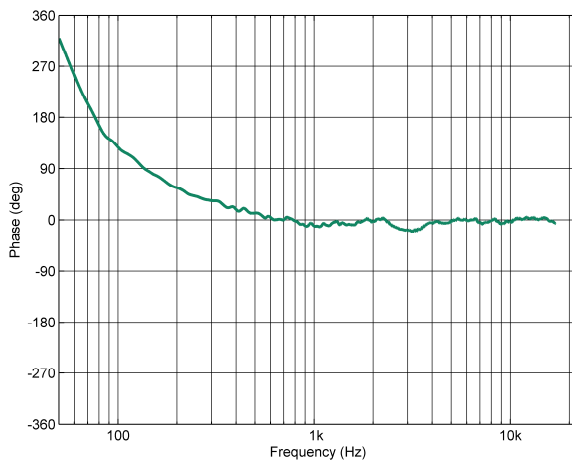

Figure 16. Phase response.