

# P80 Presentation Switcher



## Specifications

## Change History

Document Version	Release Date	Description
V1.0.1	2025-09-25	<ul style="list-style-type: none"><li>• Added CE and KC certifications.</li><li>• Added a description for reduced blanking and HBlank settings.</li><li>• Added a description for Mac mosaic.</li></ul>
V1.0.0	2025-08-20	First release

## Introduction

The P80 is PIXELHUE's new presentation switcher featuring versatile 4K connectivity including HDMI 2.0, DP 1.2 and 12G-SDI. With 12x fixed concurrent 4K inputs and a swappable P\_HDMI2.0\_DP1.2\_OPT Link Card containing 4x concurrent 4K inputs, it delivers exceptional input flexibility. The P80 comes with 8x HDMI 2.0 main output connectors allowing for up to 4x 4K concurrent main outputs (copy mode) or 8x DL concurrent main outputs (split mode). It also supports 4x 4K flex outputs, 4x 12G-SDI matrix outputs, and 2x dedicated Multiviewer outputs. Additionally, 8x 10G SFP optical ports are offered to copy the HDMI 2.0 outputs, enabling long-distance 4K signal transmission without fiber converters. The P80 supports up to 8x 4K mixing main layers and 4x 4K mixing PIP layers. Up to 256 presets and 256 layer presets can be saved for easy recall. This powerful multi-screen and multi-layer presentation switcher is ideal for medium to large-scale live events such as summit meetings, annual meetings, launch events, concerts, music festivals and exhibitions, and permanent video wall installations in hotels, shopping malls, airports, etc.

The P80 is exceptionally easy to control via any of the following options: 7-inch graphical touchscreen on the front panel, event controller U5/U5 Pro, event management software PixelFlow, or third-party control system Stream Deck. In addition, multiple P80 units can be controlled simultaneously from a single event controller/PC with PixelFlow.

The P80 ensures maximum reliability through multiple backup solutions: input source hot-backup, output copying, device backup, and dual power supply redundancy. These features enable seamless failover from primary to backup connector or device, guaranteeing uninterrupted operation during live events.

## Certifications

FCC, IC, CE, RoHS, CE, KC

**If the product does not have the relevant certifications required by the countries or regions where it is to be sold, please contact PIXELHUE to confirm or address the problem. Otherwise, the customer shall be responsible for the legal risks caused or PIXELHUE has the right to claim compensation.**

## Features

### Input and Output

- 12x fixed concurrent 4K inputs
  - 4x HDMI 2.0
  - 4x HDMI 2.0/DP 1.2 (Only one type of connector can be selected as the input source at the same time.)
  - 4x 12G-SDI
- A swappable input card: P\_HDMI2.0\_DP1.2\_OPT Link Card
  - 2x HDMI 2.0
  - 2x HDMI 2.0/DP 1.2 (Only one type of connector can be selected as the input source at the same time.)
- 8x HDMI 2.0 main output connectors

These connectors are divided into four groups and up to 4x 4K (copy mode) or 8x DL (split mode) concurrent main outputs are supported.

  - In copy mode, one of the connectors within a group copies the other's output content and the output resolution is up to 4K.
  - In split mode, both connectors within a group collaborate to output content and the output resolution of each connector is half of the content resolution. The output resolution per connector is up to DL.
- 8x OPT output ports

8x 10G SFP optical ports are offered to copy the HDMI 2.0 outputs. 4x 4K outputs are supported.
- 4x 4K flex outputs

4x HDMI 2.0 flex outputs with support for up to 4x flex screens
- 4x SDI matrix outputs
  - 4x 12G-SDI for matrix outputs
  - Allows any content from the input sources, MVR, PGM and flex outputs to be mapped to the output.
- 2x Multiviewer outputs
  - 2x HDMI 2.0 for connecting to Multiviewer screens to monitor all the input sources, PVW and PGM.
  - Allows users to select independent or copy mode and select a standard resolution and frame rate for the connectors.
    - In independent mode, 2x concurrent DL outputs are supported.
    - In copy mode, 1x 4K output and 1x copying output are supported.
  - A variety of Multiviewer layout templates are provided.
  - The Multiviewer windows can be resized and repositioned, and the width, height and color of the border can be adjusted.
  - The UMD information such as resolution and frame rate can be displayed and the font color is customizable.

- Genlock synchronization signal input and output (with support for loop-through)

## Functionality

- Multi-screen configuration
  - Main output connectors can be freely configured as independent screens or edge-blended widescreens. Flex output connectors currently can be configured as independent screens only.
  - Up to 4x 4K main screens and up to 4x 4K flex screens are supported.
  - Multi-screen mosaic

Users can arrange the mosaic layout manually or select a layout template. If a connector used for mosaic fails, it can be replaced with another normal connector in the software.
  - Edge blending

Blend the overlapping edges of the images projected by multiple projectors to ensure uniform brightness across the entire display.
  - LCD bezel compensation

Eliminate the visual disruption caused by seams in spliced LCD displays, resulting in a more unified and seamless display.
  - Virtual pixel configuration is supported, simplifying calculations between on-site screen size and P80-loaded screen pixels.
  - AOI (Area of Interest) feature to customize active areas of outputs
  - Custom test patterns

Select a test pattern for screen test and troubleshooting.
- Multi-layer management
  - Up to 8x 4K mixing main layers available for the main screens and up to 4x 4K mixing PIP layers available for the flex screens.
  - Any of the inputs, Multiviewer, PGM, or local images can be selected as the source of a layer.
  - Layers can be repositioned and resized.
  - The Z-order of layers can be adjusted.
  - Layer names are displayed and can be modified.
  - Layer resource usage are displayed in real time.
  - Layer effects such as flip, crop, mask, border, and shadow are supported. (PIP layers do not support border and shadow.)
  - DSK: Smart key, luma key, and chroma key are supported. (PIP layers do not support this feature.)
  - Cut & Fill (Flex layers do not support this feature.)

Use the original layer as a Fill layer and overlap it with the Cut layer to display the visible image of the Cut layer, allowing users to define output shapes and effects more flexibly.
  - Layer color adjustment: Brightness, contrast, saturation, hue, opacity, etc. (PIP layers do not support opacity adjustment.)
  - Layer presets: All (or a portion) of the current layer's properties (such as input source, position, size, effects, etc.) can be saved as a layer preset in PixelFlow for easy recall. Up to 256 layer presets can be saved.

- Preset recall
  - Up to 256 presets can be saved for easy recall.
  - Relative and complete presets are supported to satisfy more application requirements.
  - Allows users to select preferred parameters such as transition duration and input source to save to a preset.
  - Presets can be loaded to PVW or PGM.
- BKG settings
  - Images imported from the control computer or event controller can be used as BKG.
  - Images captured from input sources and PGM can be used as BKG.
  - One dedicated still BKG image available on each PGM output.
  - BKG can be turned on or off.
  - The BKG image can be changed and deleted.
  - The BKG storage capacity is up to 1 GB and PNG/BMP/JPG/JPEG files are supported.
  - The BKG image automatically scales to fit the screen while maintaining aspect ratio and is positioned at the bottom layer by default.
- Transition & Effects
  - Seamless transition from PVW to PGM via Take, Cut or T-bar
  - Two options for transition between PVW and PGM: Copy and Swap
  - Customizable transition duration (0.1s to 10s)
  - Fade in and out supported
  - Screen freeze and FTB (Fade to Black) supported.
- Support for 12bit/10bit/8bit video sources
- Dynamic range conversion

Convert the dynamic range format of the input source to SDR, HDR10, or HLG.
- Automatic HDCP decryption for inputs and HDCP encryption for outputs
- Visualized live monitoring of input and output connector statuses for easy troubleshooting
- EDID management on every input and output (SDI does not support this feature.)
  - Standard EDID with support for multiple standard timings such as DMT, CEA, SMPTE and VESA
  - Custom EDID with support for reduced blanking and HBlank settings
  - Advanced EDID with support for video timing parameter settings
- Compatible with EDID on Mac and support for Mac mosaic
- Input and output color adjustment

Independent adjustment of brightness and contrast for each RGB channel, plus saturation, hue, and gamma control
- 3D

Recognize and output 3D video content accurately, convert between 2D and 3D formats, and blend 3D and 2D videos for display to provide an immersive visual experience.

## Multiple Control Options

The P80 is pretty simple to control via any of the following options:

- Front panel touchscreen
- Event controller U5/U5 Pro
- Event management software PixelFlow
- Third-party control system Stream Deck (Companion integrated into the P80)

Multiple P80 units can be controlled simultaneously from a single event controller/PC with PixelFlow.

## Reliability and Stability

- Input source backup

Users can configure hot backup for input sources. If the primary source loses its signal, the system automatically switches to the backup. You can also manually switch to the backup whenever necessary.

- Output copying

In copy mode, one of the output connectors within a group copies the other's output content.

- Device backup

With device backup enabled, when a layer's input source is missing or has no signal, all output connectors for the screen immediately stop signal output, triggering a failover to the backup device.

- Dual power supply redundancy

The P80 is designed with dual power connectors, one for the primary power supply and the other as backup.

- Antistatic settings

Set the protection duration according to the actual static electricity, ensuring the display remains normal to keep events smooth and successful.

- Rugged 4RU chassis with cleanable dust filter

- The system has passed 24/7 stability tests and is proven to be stable and reliable.

## Video Source

Input	Bit Depth	Sampling Format	Supported Resolutions	Connector Bandwidth
DP 1.2	8bit	RGB 4:4:4	8192×1080@60Hz	21.6 Gbps
		YCbCr 4:4:4	4096×2160@30Hz	
		YCbCr 4:2:2	3840×2160@60Hz	
	10bit	RGB 4:4:4	8192×1080@60Hz	
		YCbCr 4:4:4	4096×2160@60Hz	
		YCbCr 4:2:2	3840×2160@60Hz	
	12bit	RGB 4:4:4	4096×2160@30Hz	

Input	Bit Depth	Sampling Format	Supported Resolutions	Connector Bandwidth
HDMI 2.0		YCbCr 4:4:4		18 Gbps
		YCbCr 4:2:2	8192×1080@60Hz 3840×2160@60Hz	
	8bit	RGB 4:4:4	4096×2160@60Hz	
		YCbCr 4:4:4	8192×1080@60Hz	
		YCbCr 4:2:2		
	10bit	RGB 4:4:4	4096×2160@30Hz	
		YCbCr 4:4:4	4096×1080@60Hz	
		YCbCr 4:2:2	4096×2160@60Hz	
	12bit	RGB 4:4:4	4096×2160@30Hz	
YCbCr 4:4:4		4096×1080@60Hz		
YCbCr 4:2:2		4096×2160@60Hz		
12G-SDI	10bit	YCbCr 4:2:2	4096×2160@60Hz	11.88 Gbps

## Appearance

### Front Panel

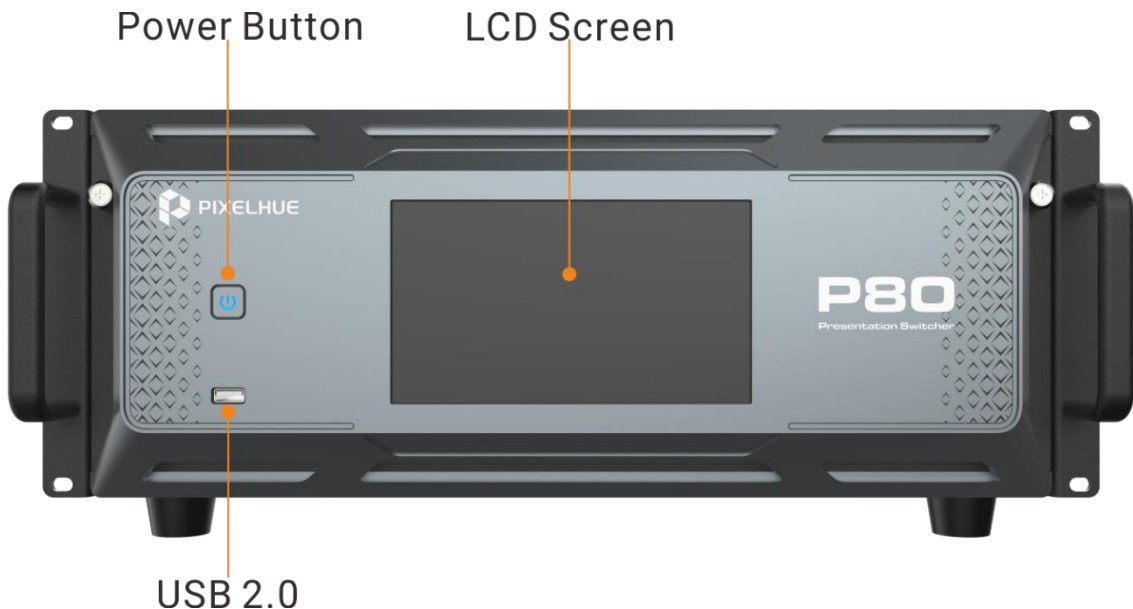

Name	Description
Power Button	Press the button to power on/off the device. To power off the device, press the button and select <b>OK</b> from the confirmation dialog box displayed on the LCD screen. Button LED status: <ul style="list-style-type: none"> <li>• Breathing: The power supply is connected.</li> </ul>

Name	Description
	<ul style="list-style-type: none"> <li>• Solid on: The device is powered on.</li> </ul>
USB 2.0	A USB 2.0 (Type A) port used to update firmware, import and export files such as logs, projects and images, connect to Stream Deck, etc.
LCD Screen	<ul style="list-style-type: none"> <li>• A 7-inch graphical touchscreen for displaying all the menus, submenus and messages</li> <li>• The device is configurable from the touchscreen.</li> </ul>

## Rear Panel

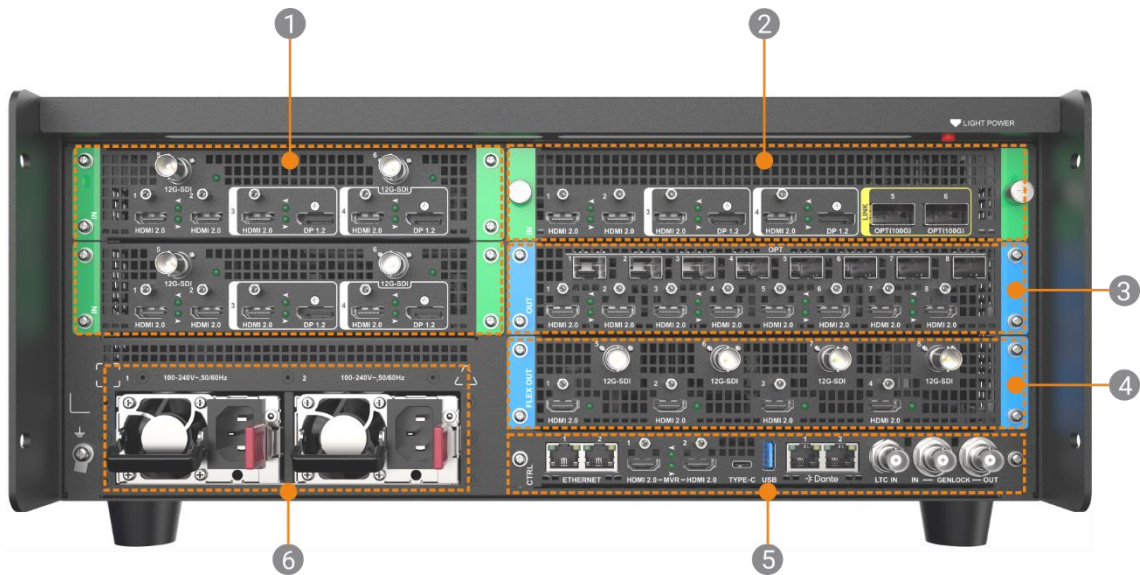

No.	Name	Qty	Description		
1	<b>Fixed input connectors</b>				
	For an input that contains an HDMI 2.0 and a DP 1.2, only one type of connector can be selected as the input source at the same time.				
	HDMI 2.0	8	Max resolution	4096×2160@60Hz 8bit 4:4:4	
			Max width/height	Max width: 8192 pixels (8192×1080@60Hz) Max height: 7680 pixels (1080×7680@60Hz)	
			Dynamic range	HDR10/HLG/SDR	
			Quantization range	Full/Limited	
			EDID management	Support for standard resolutions up to 8192×1080@60Hz Support for custom resolutions	
			HDCP	HDCP 2.2 and HDCP 1.4 compliant	
			Interlaced signal	Not supported	
DP 1.2	4	Max resolution	4096×2160@60Hz 10bit 4:4:4		
		Max width/height	Max width: 8192 pixels (8192×1080@60Hz) Max height: 7680 pixels (1080×7680@60Hz)		

No.	Name	Qty	Description	
			Quantization range	Full/Limited
			EDID management	Support for standard resolutions up to 8192×1080@60Hz Support for custom resolutions
			HDCP	HDCP 2.2 and HDCP 1.3 compliant
			Interlaced signal	Not supported
	12G-SDI	4	Standard	<ul style="list-style-type: none"> <li>Support for ST-2082 (12G), ST-2081 (6G), ST-424 (3G), ST-292 (HD), and ST-259 (SD) video inputs</li> <li>Compatible with SD-SDI, HD-SDI, 3G-SDI and 6G-SDI</li> </ul>
			Max resolution	4096×2160@60Hz 10bit 4:2:2
			EDID management	Not supported
			Interlaced signal	Supported
<b>2</b>	<b>Swappable input card: P_HDMI2.0_DP1.2_OPT Link Card</b>			
For an input that contains an HDMI 2.0 and a DP 1.2, only one type of connector can be selected as the input source at the same time.				
HDMI 2.0	4	Max resolution	4096×2160@60Hz 8bit 4:4:4	
		Max width/height	Max width: 8192 pixels (8192×1080@60Hz) Max height: 7680 pixels (1080×7680@60Hz)	
		Dynamic range	HDR10/HLG/SDR	
		Quantization range	Full/Limited	
		EDID management	Support for standard resolutions up to 8192×1080@60Hz Support for custom resolutions	
		HDCP	HDCP 2.2 and HDCP 1.4 compliant	
		Interlaced signal	Not supported	
DP 1.2	2	Max resolution	4096×2160@60Hz 10bit 4:4:4	
		Max width/height	Max width: 8192 pixels (8192×1080@60Hz) Max height: 7680 pixels (1080×7680@60Hz)	
		Quantization range	Full/Limited	
		EDID management	Support for standard resolutions up to 8192×1080@60Hz Support for custom resolutions	
		HDCP	HDCP 2.2 and HDCP 1.3 compliant	
		Interlaced signal	Not supported	
OPT (100G)	2	Link to more devices to share input sources (*to be implemented in future updates)		
<b>3</b>	<b>Main output connectors</b>			

No.	Name	Qty	Description																		
	HDMI 2.0	8	<p>8x HDMI 2.0 connectors are divided into four groups:</p> <ul style="list-style-type: none"> <li>• Group 1: HDMI 1 and HDMI 2</li> <li>• Group 2: HDMI 3 and HDMI 4</li> <li>• Group 3: HDMI 5 and HDMI 6</li> <li>• Group 4: HDMI 7 and HDMI 8</li> </ul> <p>The two connectors within a group can work in copy mode or split mode.</p> <ul style="list-style-type: none"> <li>• In copy mode, one of the connectors within a group copies the other's output content and the output resolution is up to 4K. <ul style="list-style-type: none"> <li>– Group 1: HDMI 2 copies HDMI 1.</li> <li>– Group 2: HDMI 4 copies HDMI 3.</li> <li>– Group 3: HDMI 6 copies HDMI 5.</li> <li>– Group 4: HDMI 8 copies HDMI 7.</li> </ul> </li> <li>• In split mode, both connectors within a group collaborate to output content and the output resolution of each connector is half of the content resolution. The output resolution per connector is up to DL. <ul style="list-style-type: none"> <li>– Group 1: HDMI 1 outputs the left half and HDMI 2 outputs the right half.</li> <li>– Group 2: HDMI 3 outputs the left half and HDMI 4 outputs the right half.</li> <li>– Group 3: HDMI 5 outputs the left half and HDMI 6 outputs the right half.</li> <li>– Group 4: HDMI 7 outputs the left half and HDMI 8 outputs the right half.</li> </ul> </li> </ul> <table border="1" data-bbox="576 1037 1442 1608"> <tr> <td>Max resolution</td> <td>4096×2160@60Hz 8bit 4:4:4</td> </tr> <tr> <td>Max width/height</td> <td>Max width: 8192 pixels (8192×1080@60Hz) Max height: 7680 pixels (1080×7680@60Hz)</td> </tr> <tr> <td>Bit depth</td> <td>8bit/10bit/12bit</td> </tr> <tr> <td>Sampling</td> <td>4:4:4/4:2:2</td> </tr> <tr> <td>Color space</td> <td>YCbCr/RGB</td> </tr> <tr> <td>Dynamic range</td> <td>HDR10/HLG/SDR</td> </tr> <tr> <td>EDID management</td> <td>Support for standard resolutions up to 8192×1080@60Hz Support for custom resolutions</td> </tr> <tr> <td>HDCP</td> <td>HDCP 2.2 and HDCP 1.4 compliant</td> </tr> <tr> <td>Interlaced signal</td> <td>Supported</td> </tr> </table>	Max resolution	4096×2160@60Hz 8bit 4:4:4	Max width/height	Max width: 8192 pixels (8192×1080@60Hz) Max height: 7680 pixels (1080×7680@60Hz)	Bit depth	8bit/10bit/12bit	Sampling	4:4:4/4:2:2	Color space	YCbCr/RGB	Dynamic range	HDR10/HLG/SDR	EDID management	Support for standard resolutions up to 8192×1080@60Hz Support for custom resolutions	HDCP	HDCP 2.2 and HDCP 1.4 compliant	Interlaced signal	Supported
Max resolution	4096×2160@60Hz 8bit 4:4:4																				
Max width/height	Max width: 8192 pixels (8192×1080@60Hz) Max height: 7680 pixels (1080×7680@60Hz)																				
Bit depth	8bit/10bit/12bit																				
Sampling	4:4:4/4:2:2																				
Color space	YCbCr/RGB																				
Dynamic range	HDR10/HLG/SDR																				
EDID management	Support for standard resolutions up to 8192×1080@60Hz Support for custom resolutions																				
HDCP	HDCP 2.2 and HDCP 1.4 compliant																				
Interlaced signal	Supported																				
	OPT	8	<p>10G SFP optical ports are offered to copy HDMI 2.0 outputs.</p> <ul style="list-style-type: none"> <li>• Copy mode <ul style="list-style-type: none"> <li>– OPT 1 copies the left half of the HDMI 1 output image.</li> <li>– OPT 2 copies the right half of the HDMI 1 output image.</li> <li>– OPT 3 copies the left half of the HDMI 3 output image.</li> <li>– OPT 4 copies the right half of the HDMI 3 output image.</li> <li>– OPT 5 copies the left half of the HDMI 5 output image.</li> <li>– OPT 6 copies the right half of the HDMI 5 output image.</li> <li>– OPT 7 copies the left half of the HDMI 7 output image.</li> <li>– OPT 8 copies the right half of the HDMI 7 output image.</li> </ul> </li> </ul>																		

No.	Name	Qty	Description	
			<ul style="list-style-type: none"> <li>• Split mode <ul style="list-style-type: none"> <li>– OPT 1 copies HDMI 1.</li> <li>– OPT 2 copies HDMI 2.</li> <li>– OPT 3 copies HDMI 3.</li> <li>– OPT 4 copies HDMI 4.</li> <li>– OPT 5 copies HDMI 5.</li> <li>– OPT 6 copies HDMI 6.</li> <li>– OPT 7 copies HDMI 7.</li> <li>– OPT 8 copies HDMI 8.</li> </ul> </li> </ul> <p>Each port supports up to 4K output and the transmission distance is up to 10km.</p>	
<b>4</b>	<b>Flex and matrix output connectors</b>			
	HDMI 2.0	4	Flex output connectors	
			Max resolution	4096×2160@60Hz 8bit 4:4:4
			Max width/height	Max width: 8192 pixels (8192×1080@60Hz) Max height: 7680 pixels (1080×7680@60Hz)
			Bit depth	8bit/10bit/12bit
			Sampling	4:4:4/4:2:2
			Color space	YCbCr/RGB
			Dynamic range	HDR10/HLG/SDR
			EDID management	Support for standard resolutions up to 8192×1080@60Hz Support for custom resolutions
			HDCP	HDCP 2.2 and HDCP 1.4 compliant
			Interlaced signal	Supported
	12G-SDI	4	<ul style="list-style-type: none"> <li>• Matrix outputs of the input sources, Multiviewer, and PGM</li> <li>• Compatible with HD-SDI, 3G-SDI and 6G-SDI</li> <li>• No support for bit depth and color space settings</li> </ul>	
<b>5</b>	<b>Control connectors</b>			
	ETHERNET	2	<ul style="list-style-type: none"> <li>• Gigabit Ethernet ports for device control and input view (transmission at 10fps)</li> <li>• One works as primary and the other as backup.</li> </ul>	
	MVR	2	<ul style="list-style-type: none"> <li>• HDMI 2.0 connectors for Multiviewer.</li> <li>• Two output modes are supported: <ul style="list-style-type: none"> <li>– Copy mode: 1x 4K output and 1x copying output are supported.</li> <li>– Independent mode: 2x concurrent DL outputs are supported.</li> </ul> </li> <li>• The output resolution and frame rate can be changed.</li> <li>• HDCP 2.2 and HDCP 1.4 compliant</li> </ul>	
	TYPE-C	1	USB 3.0 Type-C port for USB device connection (*to be implemented in future updates)	
	USB	1	USB 3.0 Type-A port used to update firmware, import and export files such as	

No.	Name	Qty	Description
			logs, projects and images, connect to Stream Deck, etc.
	Dante	2	Dual redundant Gigabit Ethernet ports for Dante audio networking (*to be implemented in future updates)
	LTC IN	1	For timecode input (*to be implemented in future updates)
	GENLOCK	2	Genlock synchronization signal connectors <ul style="list-style-type: none"> <li>• IN: Synchronization signal input</li> <li>• OUT: Synchronization signal output (with support for loop-through)</li> </ul>
<b>6</b>	<b>Power connectors</b>		
	100-240V~, 50/60Hz	2	<ul style="list-style-type: none"> <li>• 2x AC power connectors (100-240V, 50/60Hz)</li> <li>• One for primary power supply and the other as backup</li> </ul>

## Dimensions

### P80

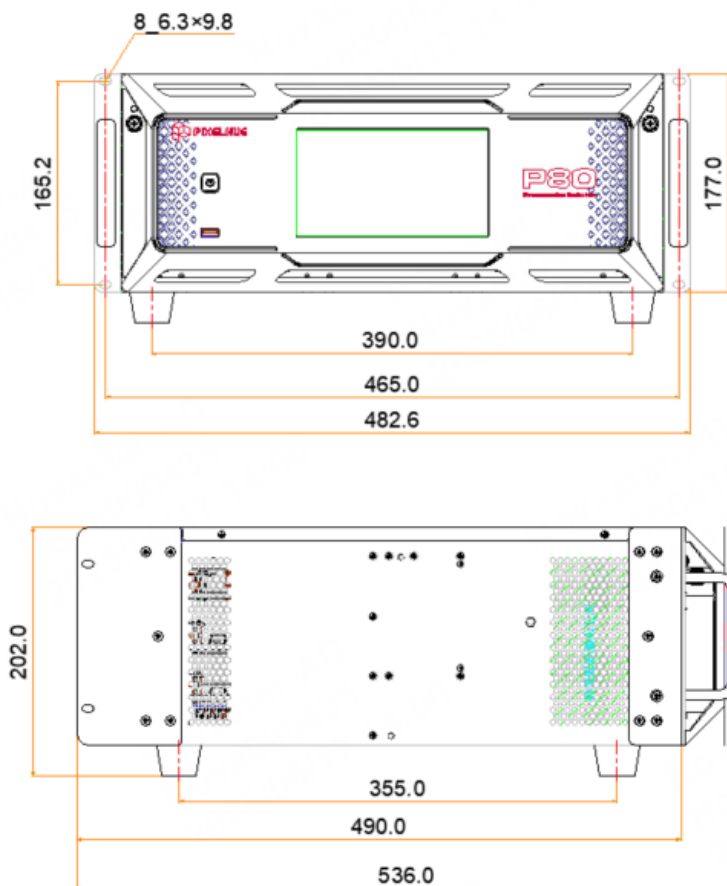

Tolerance:  $\pm 0.5$  Unit: mm

**Flight Case**

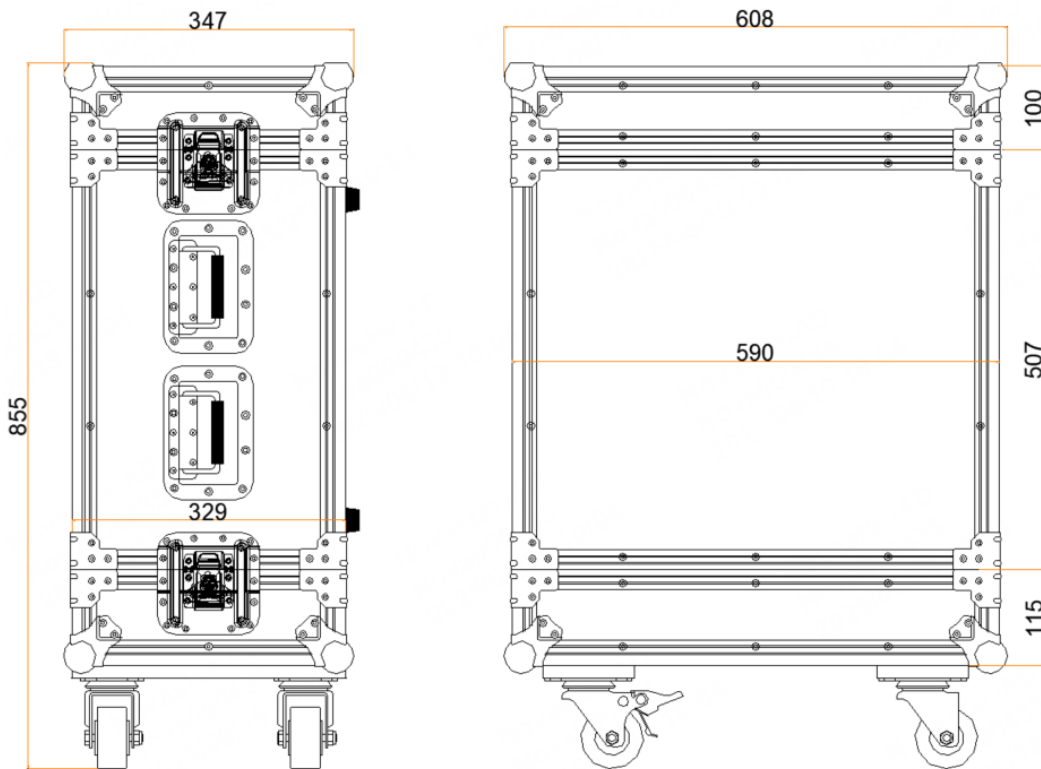

Tolerance:  $\pm 5$  Unit: mm

 **Notes**

If you require detailed dimensions and drawings of the flight case, please contact PIXELHUE customer service team.

## Applications

The P80 presentation switcher can work with the U5 or U5 Pro event controller. The following uses the U5 as an example.

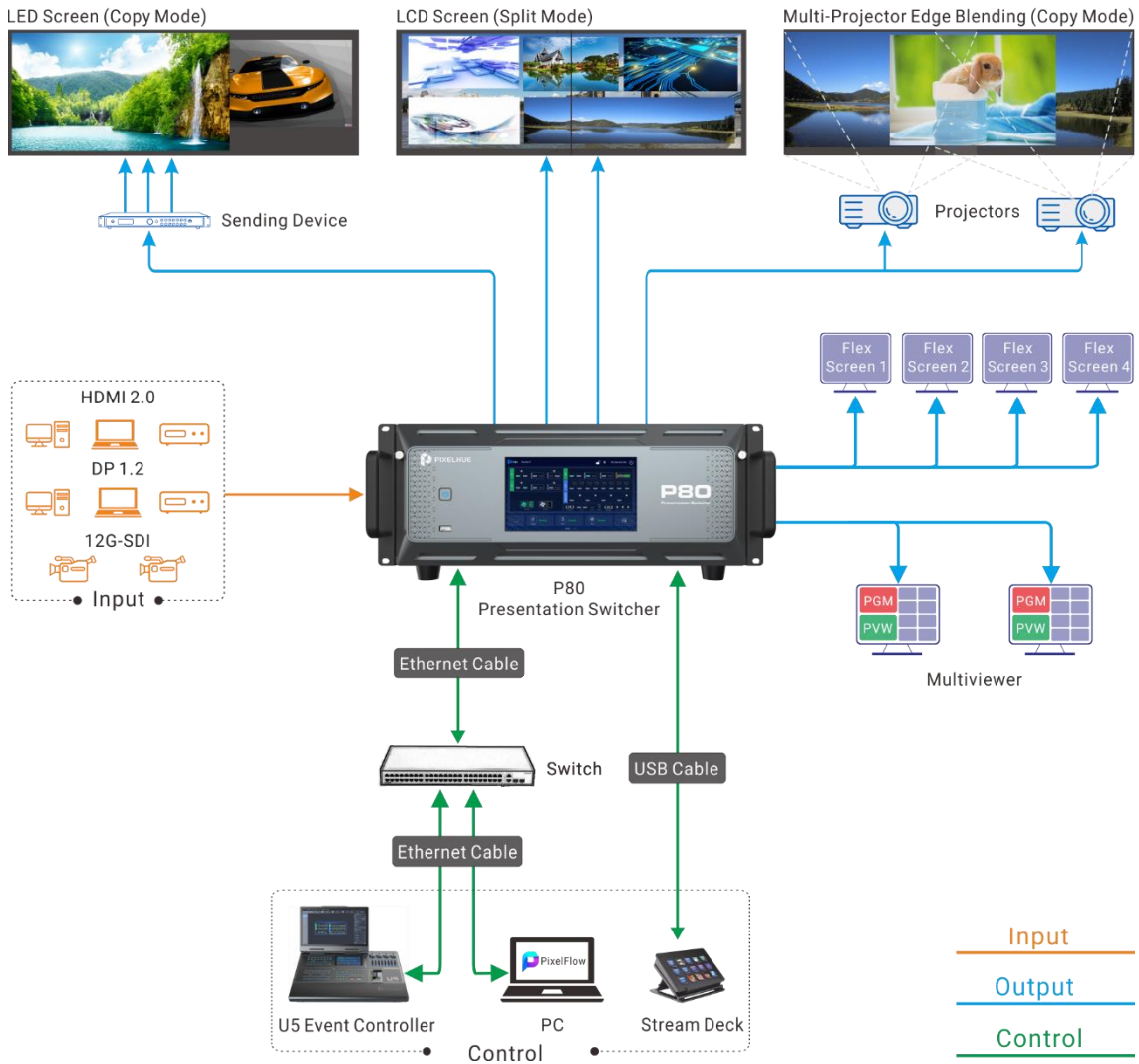

## Specifications

Electrical Specifications	Power supply	100-240V~, 50/60Hz
	Max power consumption	450 W
Operating Environment	Temperature	0°C to 50°C (32°F to 122°F)
	Humidity	5% RH to 85% RH, non-condensing
Storage Environment	Temperature	-20°C to +70°C (-4°F to 158°F)
	Humidity	5% RH to 95% RH, non-condensing
Physical Specifications	Dimensions	W 482.6 mm × D 536.0 mm × H 177.0 mm W 19.0 in × D 21.1 in × H 7.0 in

	Net weight	23.0 kg / 50.7 lbs
	Gross weight (packed with flight case)	59.6 kg / 131.4 lbs Note: It is the total weight of the product, accessories, and packing materials packed with a flight case.
Packing Information	Flight case	608 mm × 347 mm × 855 mm 24 in × 14 in × 34 in
	Accessories	<ul style="list-style-type: none"> <li>• 2x AC power cords</li> <li>• 1x DC power cord</li> <li>• 1x Ethernet cable</li> <li>• 3x HDMI cables</li> <li>• 3x DP cables</li> <li>• 8x Optical modules</li> <li>• 1x Phillips screwdriver</li> <li>• 1x Customer Letter</li> <li>• 1x Quick Start Guide</li> <li>• 1x Safety Manual</li> <li>• 1x Certificate of Approval</li> </ul>
Noise (Typical at 25°C/77°F)	45 dB (A)	

The amount of power consumption may vary depending on various factors such as product settings, usage, and environment.

## Notes and Cautions

### Notes for Installation

When the product needs to be installed on the rack, 4 screws at least M5\*12 should be used to fix it. The rack for installation shall bear at least 92.0kg weight.

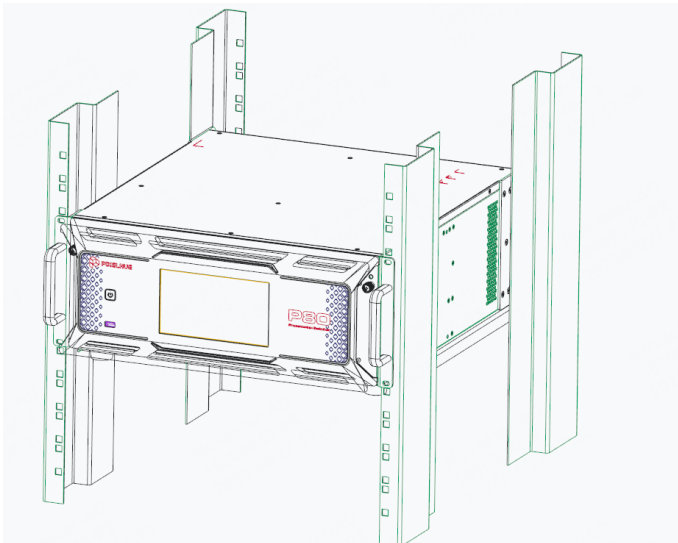

- Elevated Operating Ambient - If installed in a closed or multi-unit rack assembly, the operating ambient temperature of the rack environment may be greater than room ambient. Therefore, consideration should be given to installing the equipment in an environment compatible with the maximum ambient temperature (T<sub>ma</sub>) specified by the manufacturer.
- Reduced Air Flow – Installation of the equipment in a rack should be such that the amount of air flow required for safe operation of the equipment is not compromised.
- Mechanical Loading – Mounting of the equipment in the rack should be such that a hazardous condition is not achieved due to uneven mechanical loading.
- Circuit Overloading – Consideration should be given to the connection of the equipment to the supply circuit and the effect that overloading of the circuits might have on overcurrent protection and supply wiring. Appropriate consideration of equipment nameplate ratings should be used when addressing this concern.
- Reliable Earthing – Reliable earthing of rack-mounted equipment should be maintained. Particular attention should be given to supply connections other than direct connections to the branch circuit (e.g. use of power strips).

## FCC Caution

Any changes or modifications not expressly approved by the party responsible for compliance could void the user's authority to operate the equipment.

This device complies with part 15 of the FCC Rules. Operation is subject to the following two conditions: (1) This device may not cause harmful interference, and (2) this device must accept any interference received, including interference that may cause undesired operation.

Note: This equipment has been tested and found to comply with the limits for a Class A digital device, pursuant to part 15 of the FCC Rules. These limits are designed to provide reasonable protection against harmful interference when the equipment is operated in a commercial environment. This equipment generates, uses, and can radiate radio frequency energy and, if not installed and used in accordance with the instruction manual, may cause harmful interference to radio communications. Operation of this equipment in a residential area is likely to cause harmful interference in which case the user will be required to correct the interference at his own expense.

## Others

This is Class A product. In a domestic environment, this product may cause radio interference in which case the user may be required to take adequate measures.

This product can only be placed horizontally. Do not mount vertically or upside-down.

## Copyright

**Copyright © 2025 Pixelhue Technology Ltd. All Rights Reserved.**

No part of this document may be copied, reproduced, extracted or transmitted in any form or by any means without the prior written consent of Pixelhue Technology Ltd (hereinafter referred to as PIXELHUE).

**Trademarks**

 **PIXELHUE** is a trademark of Pixelhue Technology Ltd.

Brand and product names mentioned in this manual may be trademarks, registered trademarks or copyrights of their respective holders.

**Statement**

Thank you for choosing PIXELHUE products. This document is intended to help you understand and use the products. PIXELHUE may make improvements and/or changes to this document at any time and without prior notice. If you experience any problems in use or have any suggestions, please contact us via the contact information given in this document. We will do our best to solve any issues, as well as evaluate and implement any suggestions.

This document could contain technical inaccuracies or typographical errors. Changes are periodically made to the information in this document; these changes are incorporated in new editions of this document.

The latest edition of user manuals can be downloaded from the PIXELHUE website [www.pixelhue.com](http://www.pixelhue.com).

| [Official website](http://www.pixelhue.com)  
| [www.pixelhue.com](http://www.pixelhue.com)

| [Technical support](mailto:service@pixelhue.com)  
| [service@pixelhue.com](mailto:service@pixelhue.com)