

# Event Master family

Modular screen management systems

EVENT MASTER

BARCO

Visibly yours

# Full show control made easy

4K is a hot topic these days, and the next big thing in the AV world. By delivering four times as much resolution as 1080p Full HD, with greater texture and sharper details, 4K revolutionizes display technology and transforms image quality as we know it.

To meet and exceed these increasing expectations, Barco has developed its groundbreaking screen management systems: the Event Master series. Excelling in image quality, high I/O density, expandability, and durability, this family of products constitute the most comprehensive 4K screen management solutions on the market.

The cornerstones of this new family are the E2 and S3-4K processors. With performance second to none, the Event Master processors offer video professionals full flexibility to easily manage the most mind-blowing events – often with a single box. Did you know, for example, that up to 90% of the world’s events can be managed with a single E2 processor? And thanks to the modularity and expandability of the Event Master system, the processors can be linked to create a single cohesive system, addressing the top 10% of events.

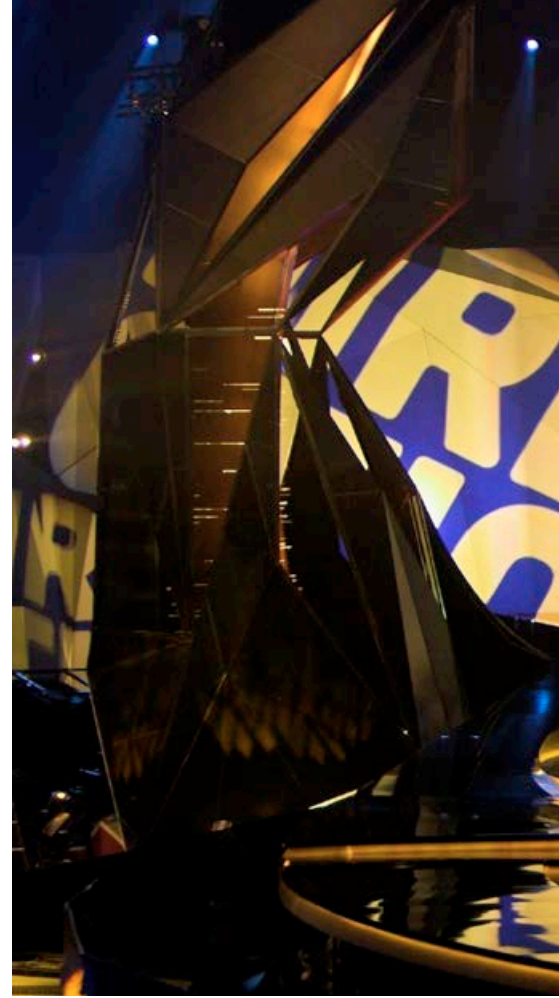

## Unmatched performance

Barco’s state-of-the-art Athena™ based image processing technology is renowned for its exceptional image quality and low processing latency. With native 4K input and output, the E2 and S3-4K processors provide impressive pixel processing power. The E2 and the S3-4K are the first screen management systems on the market to manage multiple 4K projectors blended, with refresh rates up to 60 Hz, without compressed color.

Native or scaled inputs, two connectors or four: the Event Master series can manage your 4K requirements. When HD is the requirement, the 4K processing can be subdivided to create an unmatched amount of HD input and output density, as well as PIP layers.



## Built to expand

The Event Master series excels in versatility and flexibility. The linkable chassis of the E2 and S3-4K processors allow you to link E2 to E2, and S3-4K to S3-4K. This enables easy expansion beyond the standard amount of inputs and layers without the need for additional external processing or routing to distribute the signals.\*

Growing as you add, the Event Master series offers all the tools you need to manage the most challenging and impressive events with ease. Future software releases will give you the ability to link up to four S3-4K, or link up to 16 E2’s. The choice is yours.



\* And as outputs can be expanded as well, up to 32 4K projectors can be combined into a single blended screen.



### Modularity for the future

Featuring modular I/O cards, usable across the product family, Event Master provides all the advanced features and future upgradeability a video professional needs. As new signal interfaces become reality, you simply add a new card to your E2 or S3-4K system. This, and the dual redundant power supplies make for an extremely reliable solution, and ensure great serviceability in the field: Users can easily swap a specific input or output cards in the case of damage, without having to ship or replace the entire box.

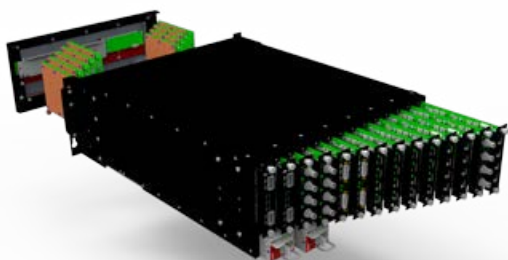

### Straightforward control

The E2 and S3-4K both come with a straightforward cross-platform user interface, the Event Master Tool-set, that provides touchscreen ergonomics. Presets are stored on the chassis, making control via third-party systems a breeze. Multiple users can control the system simultaneously, and the command structure allows third-party developers to create custom control programs and interfaces. To meet the needs of the most demanding events, Barco offers two hardware controllers, the EC-50 and EC-200. The event controllers place the show at your fingertips.



# E2

## The hero your event deserves



## Key features - standard configuration

The E2 is a ground-breaking 4K screen management system that offers video professionals unparalleled flexibility to manage the most awe-inspiring visuals. Excelling in image quality, I/O density, expandability and durability, it is the most comprehensive system of its kind currently on the market.

If the standard configuration packages don't suit your requirements, the E2 and S3-4K can be ordered in custom input and output configurations using our built-to-order configurator.

Due to the modular nature of Event Master, inputs, outputs, layers and linking can all be customized to suit your event or installation requirements.

- Up to 32 inputs, 14 outputs<sup>1</sup>
- Dedicated Multiviewer
- 8 Program outputs
- Four scaled Aux outputs
- 4K 60p 4:4:4 scaling
- Each I/O card supports 4K
- Up to 16 independent PIP mixers<sup>2</sup>
- HDCP 1.4 compliant
- EDID 1.3 compliant
- Hardware controllers available
- Live native resolution background mixer per destination
- Front-to-back forced air cooling
- Dual redundant power supplies
- Field-installable cards
- Expansion via integrated link cards
- Easy-to-use GUI control
- Widescreen blending support
- Seamless AUX switching
- Roadworthy design

1: Software allows for two E2 to be linked together for up to 28 outputs in total.  
2: Not all screen configurations support 16 mixers.

## Typical applications

- Rental and staging
- Touring
- Broadcast studios
- Simulation
- High-end corporate venues
- House of Worship

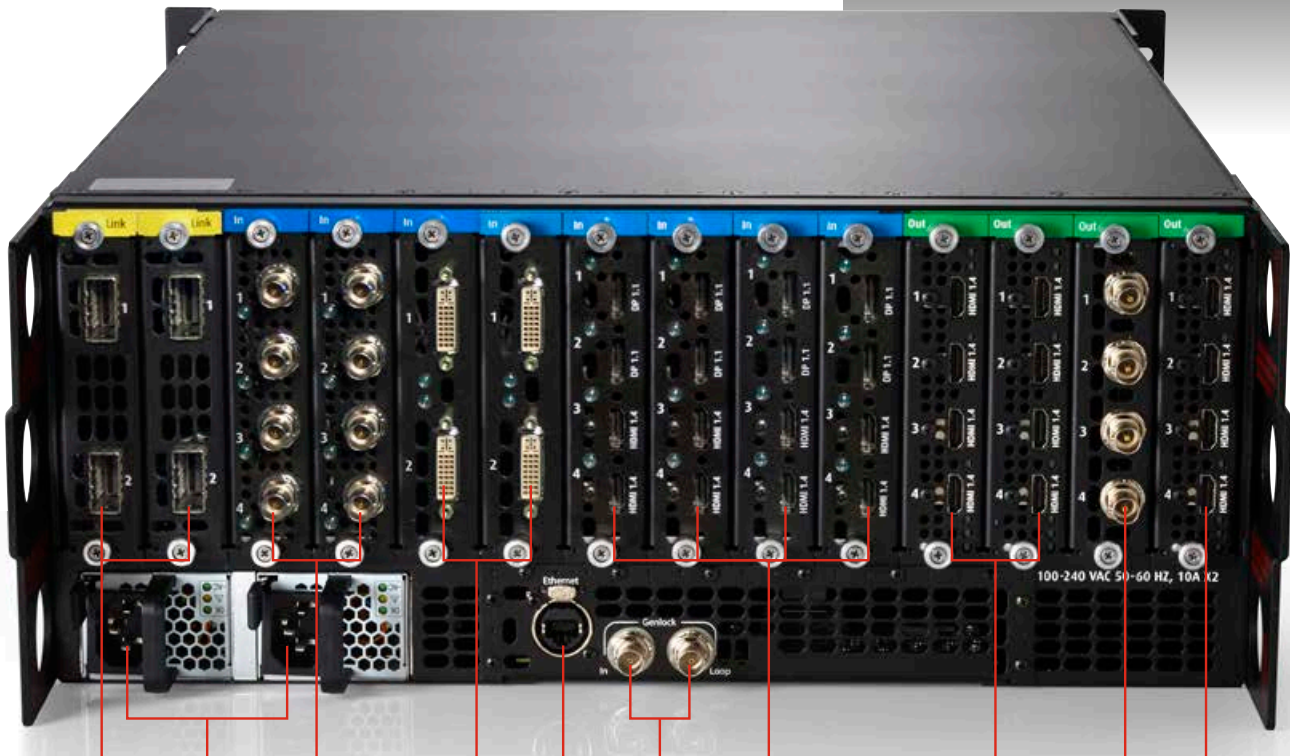

### Expansion Cards

- 2 High speed CXP connectors per card

### SDI Inputs

- 4 SDI BNC connectors per card
- SD/HD/3G formats (6G ready<sup>2</sup>)
- Each card supports one 4K/UHD signal<sup>1</sup>

### DVI Inputs

- 2 DVI-I connectors per card
- Single / Dual Link formats
- Each card supports one 4K/UHD signal<sup>1</sup>
- HDCP 1.4 / EDID 1.3

### Genlock with loop-through

### Ethernet

Connect to the PC/GUI via a ruggedized lockable RJ45 connector

### DisplayPort/HDMI Inputs

- 2 DisplayPort 1.1 and 2 HDMI 1.4a connectors per card (compatible with many locking adapters)
- Formats up to 2,048 x 2,160@60, 2,560 x 1,600@60, 3,840 x 1,200@60 and 3,840 x 2,160@30 (30 bits)
- Each card supports one 4K/UHD signal<sup>1</sup>
- HDCP 1.4 and EDID 1.3

### HDMI Outputs

- 2 HDMI connectors (compatible with many locking adapters)
- Formats up to 2,048 x 2,160@60, 2,560 x 1,600@60, 3,840 x 1,200@60 and 3,840 x 2,160@30 (30 bits)
- Each card supports one 4K/UHD signal<sup>1</sup>
- HDCP 1.4 and EDID 1.3

### Multiviewer Outputs

- 4 HDMI connectors
- Dual Output

### SDI Outputs

- 4 SDI BNC connectors
- SD/HD/3G formats (6G ready)<sup>2</sup>
- Each card supports one 4K signal

### Notes

<sup>1</sup>: Refer to the Product Specification for 4K/UHD formats  
<sup>2</sup>: 6G support via future software release

# S3-4K

Because every hero needs a sidekick

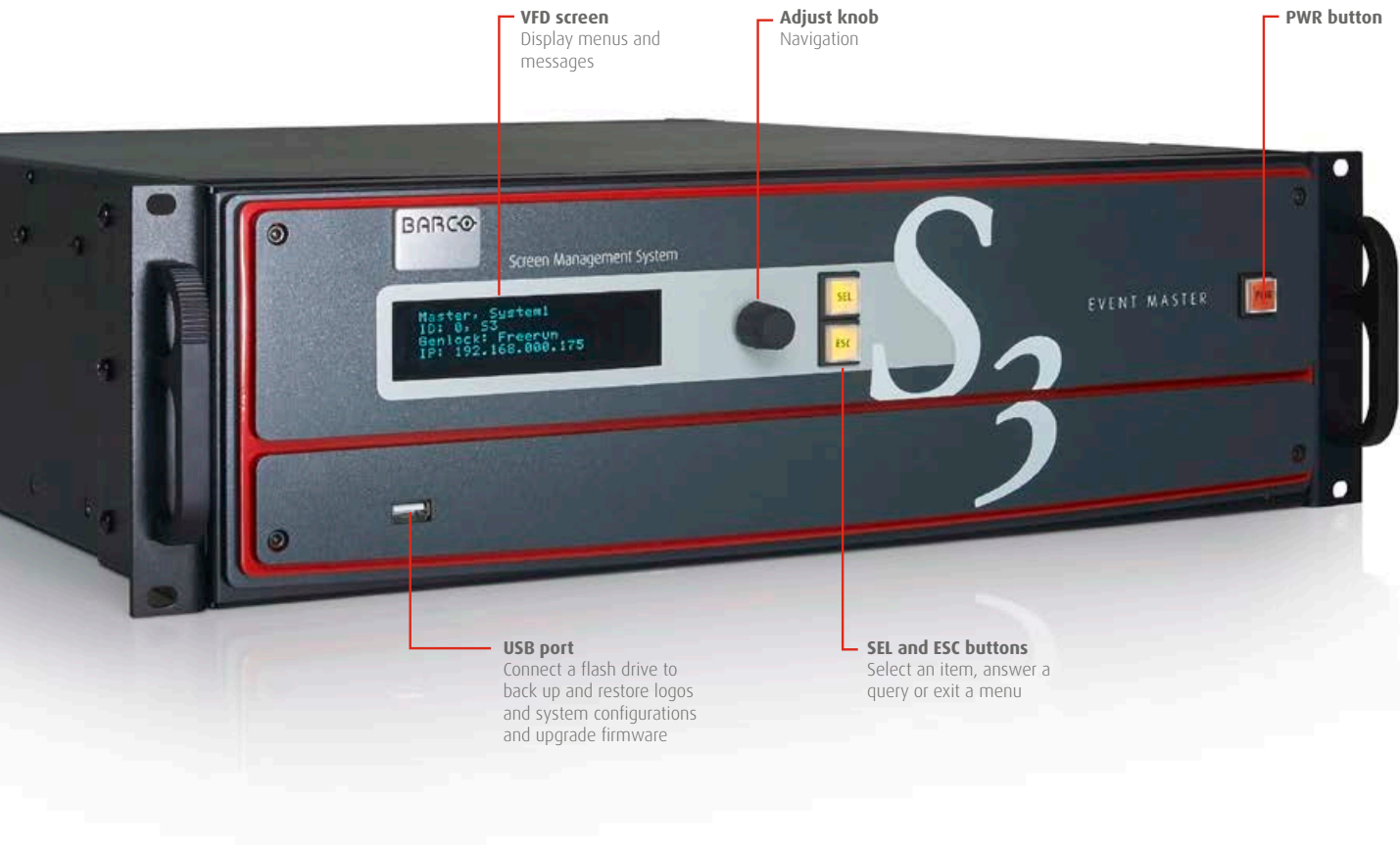

## Key features S3-4K

The S3-4K is E2's more compact sidekick, but one that can hold its own in most situations. Unparalleled flexibility, excellent image quality, incredible I/O density and durability to create moments that last, all in a compact and road-worthy enclosure.

The S3-4K utilizes the same modular cards as the E2. In addition to being serviced in the field, this feature makes the S3-4K ready for future signal interfaces.

- 12 inputs
- 4 PGM outputs
- 4 AUX outputs
- 2 Dedicated Multiviewer outputs
- Genlockable
- 4 mixable 2K PIPs
- HDCP 1.4 compliant
- EDID 1.3 compliant
- 4-projector blend from a single box
- Hardware controllers available
- Live native resolution background mixer per destination
- Front-to-back forced air cooling
- Dual redundant power supplies
- Field-installable cards
- Expansion via integrated link cards
- Easy-to-use, cross platform GUI control
- Widescreen blending support
- Seamless AUX switching
- Roadworthy design

## Typical applications

- Rental and staging
- Touring
- Broadcast studios
- Simulation
- High-end corporate venues
- House of Worship
- Mid-sized performance venues

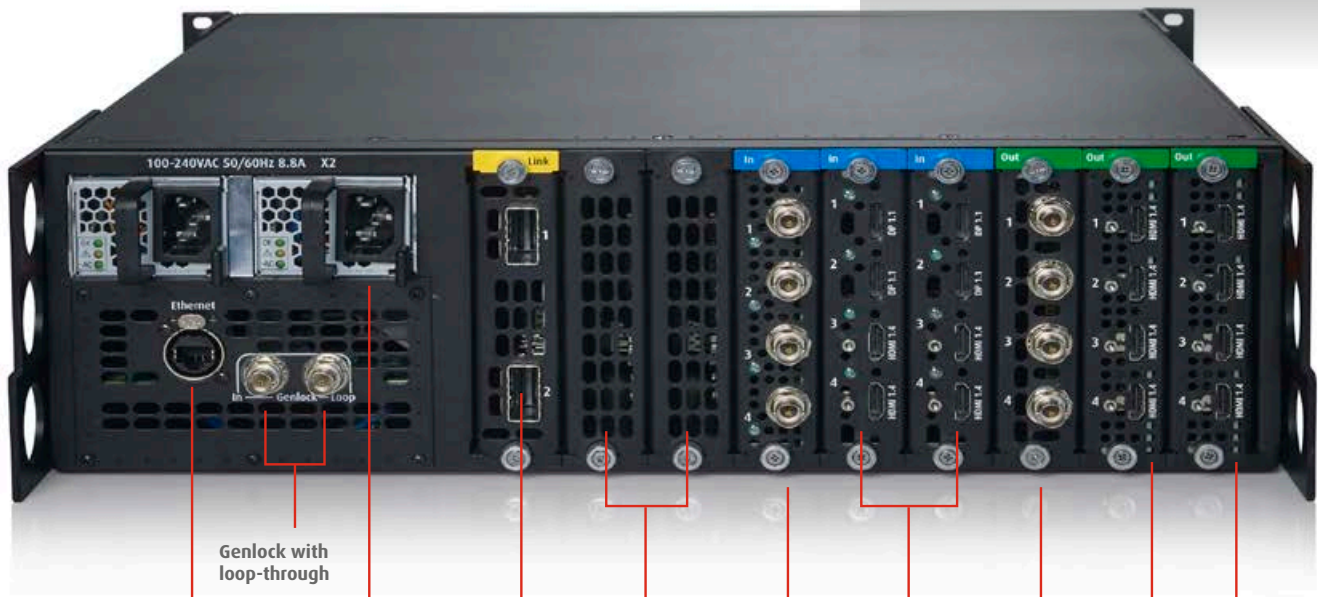

Genlock with loop-through

**Ethernet**  
Connect to the PC/GUI via a ruggedized lockable RJ45 connector

**Dual Redundant Power Supplies**

**Expansion Card**  
• 2 High speed CXP connectors

**Video processing Cards**

**SDI Inputs**  
• 4 SDI BNC connectors  
• SD/HD/3G formats (6G ready)<sup>2</sup>  
• Each card can support one 4K signal

**DisplayPort/HDMI Inputs**  
• 2 DisplayPort and 2 HDMI connectors (compatible with many locking adapters)  
• Formats up to 2,048 x 2,160@60, 2,560 x 1,600@60, 3,840 x 1,200@60 and 3,840 x 2,160@30 (30 bits)  
• Each card supports one 4K/UHD signal<sup>1</sup>  
• HDCP 1.4 and EDID 1.3

**SDI Outputs**  
• 4 SDI BNC connectors  
• SD/HD/3G formats (6G ready)<sup>2</sup>  
• Each card supports one 4K signal

**HDMI Outputs**  
• 4 HDMI connectors (compatible with many locking adapters)  
• Formats up to 2,048 x 2,160@60, 2,560 x 1,600@60, 3,840 x 1,200@60 and 3,840 x 2,160@30 (30 bits)  
• Each card supports one 4K/UHD signal<sup>1</sup>  
• HDCP 1.4 and EDID 1.3

**Multiviewer Outputs**  
• 4 HDMI connectors  
• Dual Output

### Notes

1: Refer to the Product Specification for 4K/UHD formats  
2: 6G support via future software release

# What E2 can do for you

As show producers can get really creative, you need to be ready to support the most challenging setups. E2's versatility enables you to meet the wildest creative requirements. Get inspired by these examples of display lay-outs supported by E2.

## Application 1\*

### 2 PGM outputs supporting

- 2 4K 4:4:4 @60Hz displays (also supports blending)

### 1 AUX output supporting

- 1 4K downstage monitor

### Dedicated Multiviewer

- User configurable for inputs and outputs

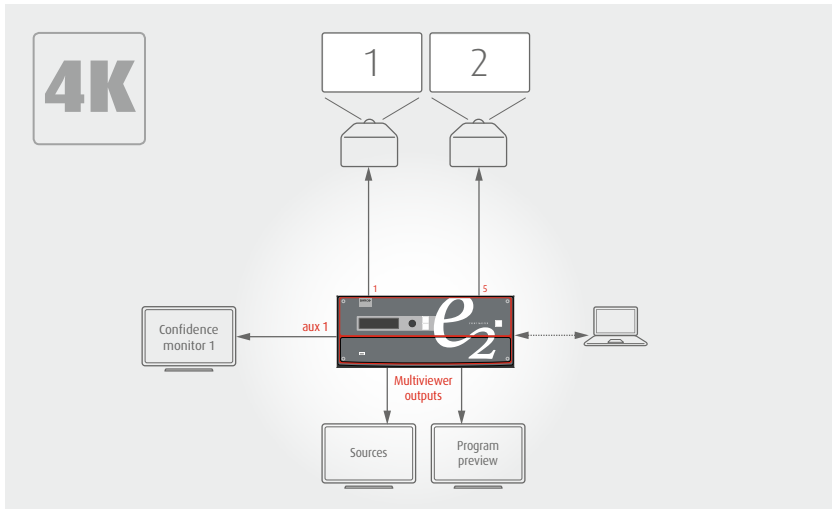

## Application 2\*

### 16 PGM outputs supporting

- 1 4x3 Main Video Wall
- 1 2x2 Side Video Wall

### 8 AUX outputs supporting

- 4 confidence monitor
- 4 downstage monitors

### Dedicated Multiviewer

- User configurable for inputs and outputs

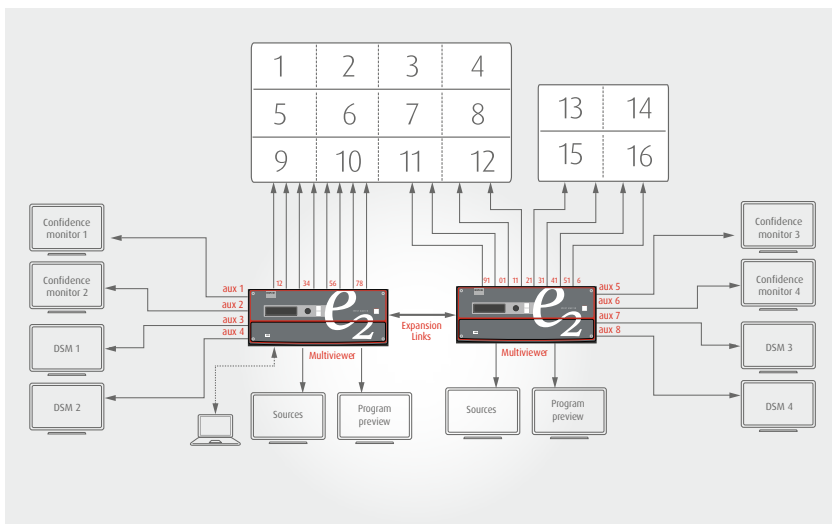

## Application 3\*

### 8 PGM outputs supporting

- 1 center screen 4-projector blend
- 2 side single projector screens
- 1 on-stage confidence monitor
- 1 record output

### 4 AUX outputs supporting

- 1 record output
- 3 DSM monitors

### Dedicated Multiviewer

- User configurable for inputs and outputs

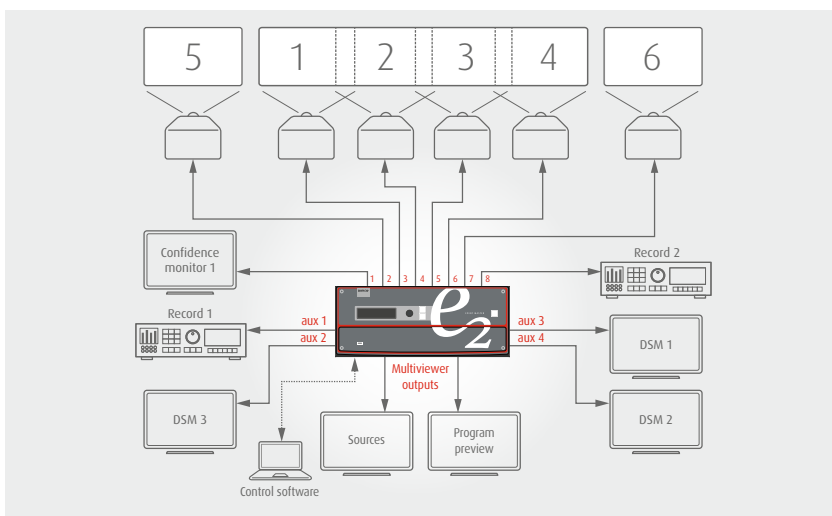

\* Assuming each output is 1080p format

# What S3-4K can do for you

Unbridled creativity and ultimate ease-of-use: that's what the S3-4K is all about. Thanks to its powerful features, E2's trusted sidekick can handle the most complex setups. The only limit is your imagination. Get inspired by these examples of display lay-outs supported by S3-4K.

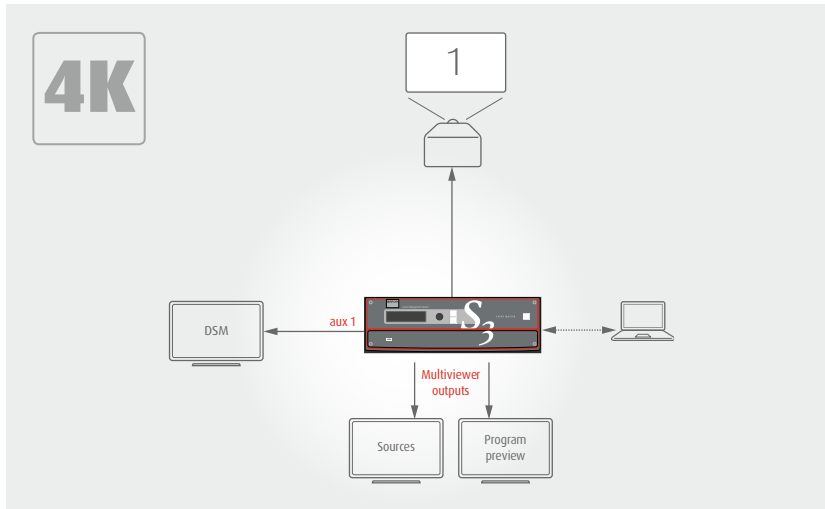

## Application 1

### PGM output supporting

- 1 4K 4:4:4 @60 Hz display

### 1 AUX output supporting

- 1 4K downstage monitor

### Dedicated Multiviewer

- User configurable for inputs and outputs

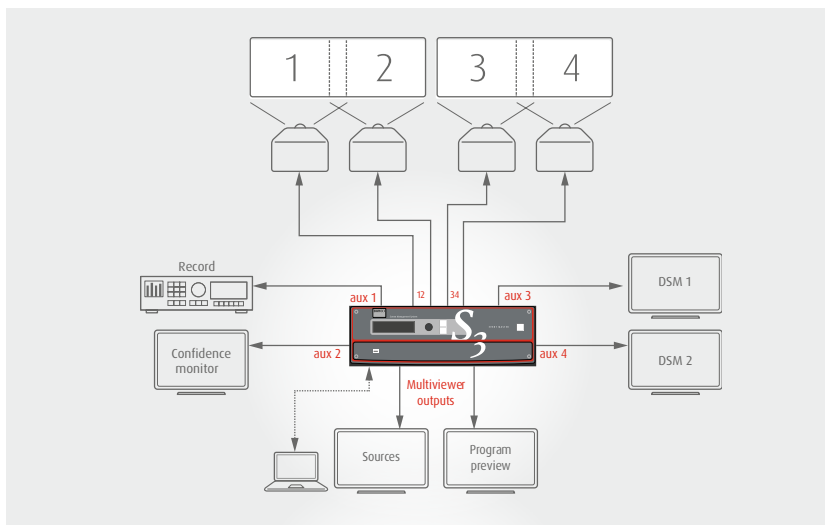

## Application 2

### 4 PGM outputs supporting

- 2 center screens, each with a 2-projector blend

### 4 AUX outputs supporting

- 1 record output
- 1 confidence monitor
- 2 downstage monitors

### Dedicated Multiviewer

- User configurable for inputs and outputs

# Take control...

The Event Master screen management systems come with the Event Master Toolset, a cross-platform GUI-based user interface that provides touchscreen ergonomics and ease-of-use. The Event Master Toolset enables users to interface with E2 or S3-4K from a PC or Mac via an Ethernet connection. The program provides a step-by-step approach to configuring, programming presets, setting up the dedicated Multiviewer, and managing system functions.

## ...in 3 easy steps

The 3 key screens of the GUI include:

### 1. System configuration

The System configuration screen is the first to appear when you launch the GUI software. Here you can add or remove devices to the selected systems and modify their parameters (inputs, backgrounds, outputs and destinations).



### 2. Programming screen

Use the Programming screen to bring the different elements together and build your show. Define sources for inputs, modify layer attributes like size and border, and create user keys and presets.

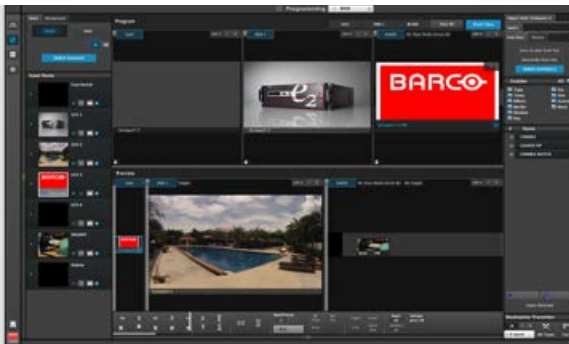

### 3. Multiviewer

In the Multiviewer screen, you can configure the dedicated Multiviewer, which enables multiple sources (inputs, backgrounds and destinations) to be displayed on one or two monitors. Up to 4 custom layouts can be created for the Multiviewer.

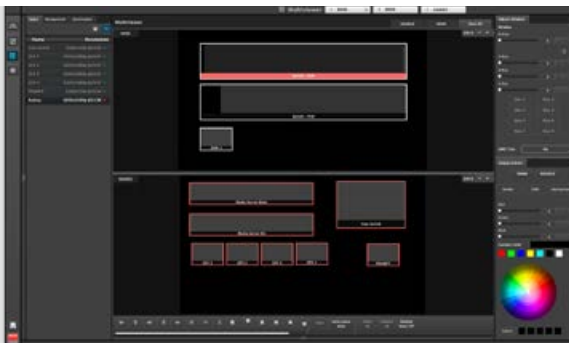

# Event Master event controllers

## Full control at your fingertips

An innovative take on the classic video controller, the Event Master event controllers give operators instant access to resources and great situational awareness for a wide range of shows, from a tradeshow booth, to a large corporate event, to a music tour. Running the same Event Master toolset as the Mac or PC, the EC-200 adds a syntax-based programmer that dramatically speeds up the ability to create large show layouts quickly and efficiently. For full-sized events, the EC-200 provides the operator with everything needed to program and execute the biggest shows possible. The small footprint of the EC-50 make it a perfect fit for smaller events.



### EC-50 & EC-200 common features

- Finger-tip control of the Event Master video processors
- 36 user-programmable buttons with customizable LCD displays and multi-page selection
- High-resolution T-bar for manual transitions
- 8 dedicated layer selection buttons with multi-page selection and dedicated BG layer button
- 12 user-definable destination buttons with multi-page selection

### EC-200 features

- Advanced control of the Event Master video processors with live source selection on program
- 2 internal 15.6-inch wide-screen touch screens with 10 point multi-touch Full HD displays
- Dedicated programming section with new syntax-based programming
- Stand-alone controller featuring a custom Linux OS and built-in CPU
- Backlit trackball with rotary encoder for the third axis, 4 configurable buttons for cursor and position control, and rotary encoder wheels for common layer adjustments (position, size etc.).



**Order numbers:**

- E2 R9004698
- S3-4K R9004757
- EC-50 R9004772
- EC-200 R9004771

**M00547-R02-0216-PB February 2016**  
Any item contained in this datasheet may change without notice.

3078 Prospect Park Drive,  
Rancho Cordova, CA 95670, USA  
T +1 916 859 2500 - F +1 916 859 2515

**Barco nv**  
Pres. Kennedypark 35,  
8500 Kortrijk, Belgium  
T +32 56 36 80 47 - F +32 56 36 83 86  
email: sales.events@barco.com

**BARCO**

Visibly yours